

Parametric Transformation of Timed Weighted Marked Graphs: Applications in Optimal Resource Allocation

Zhou He, *Member, IEEE*, Ziyue Ma, *Member, IEEE*, Zhiwu Li, *Fellow, IEEE*, and Alessandro Giua, *Fellow, IEEE*

Abstract—Timed weighted marked graphs are a subclass of timed Petri nets that have wide applications in the control and performance analysis of flexible manufacturing systems. Due to the existence of multiplicities (i.e., weights) on edges, the performance analysis and resource optimization of such graphs represent a challenging problem. In this paper, we develop an approach to transform a timed weighted marked graph whose initial marking is not given, into an equivalent parametric timed marked graph where the edges have unitary weights. In order to explore an optimal resource allocation policy for a system, an analytical method is developed for the resource optimization of timed weighted marked graphs by studying an equivalent net. Finally, we apply the proposed method to a flexible manufacturing system and compare the results with a previous heuristic approach. Simulation analysis shows that the developed approach is superior to the heuristic approach.

Index Terms—Discrete event system, resource allocation, timed Petri net, weighted marked graph.

LIST OF SYMBOLS

$P = \{p_1, p_2, \dots, p_n\}$	Finite set of places.
$T = \{t_1, t_2, \dots, t_m\}$	Finite set of transitions.
Pre	$P \times T \rightarrow \mathbb{N}$ is an output function, where $\mathbb{N} = \{0, 1, 2, \dots\}$.

Manuscript received February 28, 2020; revised May 5, 2020, June 8, 2020; accepted June 10, 2020. This work was supported by the National Natural Science Foundation of China (61803246, 61703321), the China Postdoctoral Science Foundation (2019M663608), Shaanxi Provincial Natural Science Foundation (2019JQ-022 and 2020JQ-733), the Fundamental Research Funds for the Central Universities (JB190407), and the Shaanxi Key Laboratory of Complex System Control and Intelligent Information Processing, Xi'an University of Technology (SKL2020CP03). Recommended by Associate Editor Xiaou Li. (*Corresponding author: Zhiwu Li.*)

Citation: Z. He, Z. Y. Ma, Z. W. Li, and A. Giua, "Parametric transformation of timed weighted marked graphs: applications in optimal resource allocation," *IEEE/CAA J. Autom. Sinica*, vol. 8, no. 1, pp. 179–188, Jan. 2021.

Z. He is with the College of Mechanical and Electrical Engineering, Shaanxi University of Science and Technology, Xi'an 710021, China, and also with Shaanxi Key Laboratory of Complex System Control and Intelligent Information Processing, Xi'an University of Technology, Xi'an 710048, China (e-mail: hezhou@sust.edu.cn).

Z. Y. Ma is with the School of Electro-Mechanical Engineering, Xidian University, Xi'an 710071, China (e-mail: maziye@xidian.edu.cn).

Z. W. Li is with the School of Electro-Mechanical Engineering, Xidian University, Xi'an 710071, and also with Institute of Systems Engineering, Macau University of Science and Technology, Taipa 999078, Macau, China (e-mail: zhwli@xidian.edu.cn).

A. Giua is with the Department of Electrical and Electronic Engineering, University of Cagliari, Cagliari 09124, Italy (e-mail: giua@unica.it).

Color versions of one or more of the figures in this paper are available online at <http://ieeexplore.ieee.org>.

Digital Object Identifier 10.1109/JAS.2020.1003477

$Post$	$P \times T \rightarrow \mathbb{N}$ is an input function.
C	$C = Post - Pre$ the incidence matrix.
N	PN $N = (P, T, Pre, Post)$.
$\delta = [\delta_1, \delta_2, \dots, \delta_n]^T$	Firing delay vector.
M	Marking of a Petri net (PN).
$M(p_i)$	Number of tokens in p_i at marking M .
$\langle N, M \rangle$	A Petri net system.
$x = [x_1, \dots, x_m]^T$	(minimal) T-semiflow of a PN.
$y = [y_1, \dots, y_n]^T$	(minimal) P-semiflow of a PN.
$t_{in(p_i)}$	Unique input transition of p_i .
$t_{out(p_i)}$	Unique output transition of p_i .
$v(p_i)$	Weight of the output arc of p_i .
$w(p_i)$	Weight of the input arc of p_i .
\gcd_{p_i}	Greatest common divisor of $w(p_i)$ and $v(p_i)$.
$\bullet p$	Set of input transitions of p .
p^\bullet	Set of output transitions of p .
$\bullet t$	Set of input places of t .
t^\bullet	Set of output places of t .
γ	Elementary circuit in a PN.
Γ	Set of elementary circuits.
y_γ	Minimal P-semiflow of γ .
$\chi(M)$	Cycle time of a PN system.
$\beta = 1/\chi(M)$	Throughput of a PN system.
b	Upper bound of the cycle time.
\hat{N}_{t_i}	Equivalent subnet of t_i .
\hat{M}_{t_i}	Equivalent submarking of t_i .
\hat{N}_{p_i}	Equivalent subnet of p_i .
\hat{M}_{p_i}	Equivalent submarking of p_i .
\hat{N}	Equivalent timed marked graph (TMG).
\hat{M}	Marking of an equivalent TMG.
$\langle \hat{N}, \hat{M} \rangle$	Equivalent TMG system.
$\mu(p_i^s)$	Number of tokens in place p_i^s .
$\phi_i = v(p_i) \cdot x_{out(p_i)}$	Period of p_i .
$\mathcal{G}(M, \hat{N}, \hat{M})$	Equivalent parametric TMG system.
$\mathcal{M}_{p_i}^{k_i}$	Marking set of p_i .
n_i	Number of places of \hat{N}_{p_i} .
\hat{n}	Number of places of \hat{N} .
\hat{m}	Number of transitions of \hat{N} .

I. INTRODUCTION

MANY artificial systems that consist of a limited quantity of resources shared by different tasks can be classified

as resource allocation systems [1]; among them include flexible manufacturing systems, traffic transportation systems, and logistics systems [2]–[7]. Performance of flexible manufacturing systems is usually affected by timing specifications and resource allocation. For the sake of improving productivity and saving cost considerations, the resources of a flexible manufacturing system must be well allocated. The resource optimization of manufacturing systems with operation delay, assembly, disassembly, and batch processing, is a challenging problem for manufacturing engineers.

Timed Petri nets (TPNs) are a model of discrete event systems that are widely applied to control, performance evaluation, and fault diagnosis in timed systems, e.g., flexible manufacturing systems [8]–[11]. As an important subclass of TPNs, timed marked graphs (TMGs) are suitable to model and analyze synchronization appearing in discrete event systems [12], [13].

The performance of a system modeled with TMGs was usually characterized by the cycle time. When the initial marking of a TMG is given, a linear programming is developed to estimate the cycle time [14]. The properties of cyclic TMGs were explored in [15] and it was shown that the evolution of cyclic TMGs is periodic. Therefore, it is possible to estimate the cycle time by analyzing its periodical behaviors. In addition, the linear algebraic approaches can also be applied to model and analyze the dynamic behavior of TMGs [16], [17].

To make a trade-off between the throughput of manufacturing systems and the resource cost, two main resource optimization problems were investigated in the literature: marking optimization [18] and cycle time optimization [19], [20]. The marking optimization problem finds a minimal cost marking such that the system's cycle time does not fall short of a predefined upper bound and the cycle time optimization problem investigated in [20] explores a minimal cycle time marking such that the cost of the machines/resources does not exceed an upper bound. Deadlock control of flexible manufacturing systems is another important problem that has been extensively investigated in a class of Petri nets (PNs) [21]–[23].

For modelling, analyzing, and controlling flexible manufacturing systems with batch processing, a possible method is to use timed weighted marked graphs (TWMGs) [24]. TWMGs have been proven to be adequate for performance evaluation and resource optimization of job-shops, kanban systems, and flexible manufacturing systems that are decision free [14], [15]. In such nets, each place has a unique output transition and a unique input transition but the weights on edges may be greater than one, to represent multiple edges. The behaviors and properties of TWMGs were investigated in [25]. Due to the existence of multiplicities (weights) on edges, the analysis of TWMGs is a challenging problem. When the initial marking of a TWMG is given, its cycle time could be analyzed by converting to an equivalent TMG [26], [27] using the well-known linear programming approach in [14]. However, when the initial marking becomes a decision variable to be determined for an optimization

problem, the approaches developed in [26], [27] cannot be directly used. Heuristic methods were developed in [28], [29] for the marking optimization problem of TWMGs to obtain a sub-optimal solution.

By transforming a TWMG whose initial marking is unknown into a finite number of equivalent TMG classes, an optimal initial marking can be obtained by solving a mixed integer linear programming problem for each equivalent TMG class [30], [31]. However, these approaches have high computational cost since the number of equivalent TMG classes increases exponentially w.r.t. the number of places of the original TWMG. In practice it is inefficient to solve a resource optimization problem by exploring all the equivalent TMGs¹.

To this end, this paper proposes a method to convert a TWMG whose initial marking is unknown to an equivalent parametric TMG system that fully describes the finite family of TMGs equivalent to the original TWMG. Using this transformation, a resource optimization problem for the original TWMG can be reduced to an optimization problem for the equivalent parametric TMG, which, as shown later, can be solved more efficiently. Particularly, this approach is used to handle the marking optimization of TWMGs by solving a mixed integer quadratically constrained programming problem for the equivalent parametric TMG system. To the best of our knowledge, the existing results for the marking optimization problem of TWMGs are all based on heuristic strategies.

The main contributions of this work are as follows:

- 1) We develop an approach to transform a TWMG, whose initial marking is not given, into an equivalent parametric TMG system that fully describes the finite family of TMGs equivalent to the original TWMG.
- 2) We propose a mixed integer quadratically constrained programming problem for the marking optimization problem of TWMGs.
- 3) We test the proposed approach on different cases and compare its performance with a previous heuristic approach.

This paper is organized in six sections. The basics of PNs are given in Section II. A method developed in [26] to transform a TWMG whose initial marking is given into an equivalent TMG is introduced in Section III. In Section IV, an approach to transform a TWMG whose initial marking is not given into an equivalent parametric TMG system is presented. In Section V, an analytical approach for the resource optimization problem is developed based on the equivalent parametric TMG system. In Section VI, we give the conclusions.

II. BACKGROUND

A. Petri Nets

A Petri net (PN) is a four-tuple $N = (P, T, \mathbf{Pre}, \mathbf{Post})$, where $P = \{p_1, \dots, p_n\}$ is a set of n places, $T = \{t_1, \dots, t_m\}$ is a set of m transitions with $P \cup T \neq \emptyset$ and $P \cap T = \emptyset$, $\mathbf{Pre} : P \times T \rightarrow \mathbb{N}$ and $\mathbf{Post} : P \times T \rightarrow \mathbb{N}$ are the pre-incidence and post-incidence

¹ Although several techniques that may help to speed up the approaches in [30], [31] are developed, these procedures are still subject to high computational complexity.

functions, specifying the arcs from places to transitions and transitions to places, respectively, where \mathbb{N} denotes the set of non-negative integers. Specifically, for $p \in P$ and $t \in T$, $Pre(p, t) = k > 0$ (respectively, $Post(p, t) = k$) if there exists an arc with weight k from p to t (respectively, t to p), and is 0 otherwise. **Pre** (**Post**) can be tabulated in a rectangular array and represented by an $n \times m$ matrix indexed by P and T . The incidence matrix of N is defined as $C = Post - Pre \in \mathbb{Z}^{n \times m}$, where \mathbb{Z} denotes the set of integers.

A vector $x \in \mathbb{N}^m$ (respectively, $y \in \mathbb{N}^n$) such that $C \cdot x = \mathbf{0}$ (respectively, $y^T \cdot C = \mathbf{0}$) is a T-semiflow (respectively, P-semiflow). The support of a T-semiflow (respectively, P-semiflow) is defined by $\|x\| = \{t_i \in T | x_i > 0\}$ (respectively, $\|y\| = \{p_i \in P | y_i > 0\}$). A P-semiflow (respectively, T-semiflow) is said to be minimal if $\|y\|$ (respectively, $\|x\|$) is not a superset of the support of any other P-semiflow (T-semiflow), and its elements are coprime.

A marking is a mapping $M : P \rightarrow \mathbb{N}$ that assigns to each place of a PN a non-negative integer of tokens. The marking of place p is denoted by $M(p)$. A Petri net system $\langle N, M \rangle$ is a net N with a marking M .

A PN is said to be ordinary if all the weights of its arcs are unitary. A marked graph (MG) is an ordinary PN such that for all $p \in P$, $|\bullet p| = |p \bullet| = 1$ holds, where $\bullet p$ and $p \bullet$ denote the set of input and output transitions of p , respectively. The notions for $\bullet t$ and $t \bullet$ are analogously defined. A weighted marked graph (WMG) is a PN such that for all $p \in P$, $|\bullet p| = |p \bullet| = 1$ holds, while the weights on arcs are integers.

Given a PN N , a *path* is a sequence of nodes $o_1 o_2 \dots o_k$ where $o_i \in P \cup T$ for all $i \in \{1, \dots, k\}$ such that $o_{i+1} \in o_i \bullet$ holds for all $i \in \{1, \dots, k-1\}$. A PN is cyclic if for any $o, o' \in P \cup T$, there exists a path from o to o' . A path $o_1 o_2 \dots o_k$ is a circuit if $o_1 = o_k$. A circuit $o_1 o_2 \dots o_k o_1$ is an elementary circuit, denoted by γ , if for all $i, j \in \{1, \dots, k\}$, $i \neq j$ implies $o_i \neq o_j$. We denote the set of elementary circuits by Γ . In the sequel, cyclic WMGs will be considered.

Consider a WMG with a place as shown in Fig. 1. The weights of input arc and output arc of p_i are denoted by integers $w(p_i)$ and $v(p_i)$, respectively. In addition, we use gcd_{p_i} to represent the greatest common divisor of $w(p_i)$ and $v(p_i)$.

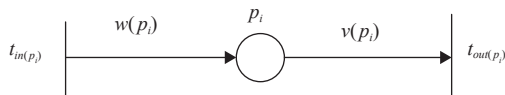

Fig. 1. A place p_i with an input transition $t_{in(p)}$ and an output transition $t_{out(p)}$.

B. Cycle Time of TWMGs

There mainly exist three ways of introducing the timing parameters in PN models, i.e., a delay can be associated with transitions, places, or arcs [32]. In this paper, we consider TPNs, in which each transition is associated with a deterministic firing delay. A timed PN is a pair (N, δ) , where N is a PN, and $\delta : T \rightarrow \mathbb{N}$ is a firing delay function that assigns to each transition a non-negative integer [30]. The single server semantic is considered in this paper, which means that

at each time an enabled transition cannot fire more than once. More details can be found in [32].

For a TWMG system $\langle N, M \rangle$, the cycle time is defined as the average period to fire one time the minimal T-semiflow as soon as possible, denoted by $\chi(M)$. In [14], a linear programming was developed to obtain a cycle time lower bound as follows:

$$\begin{aligned} & \max \beta \\ & \text{s.t. } C \cdot \alpha - Pre \cdot \delta \cdot \beta + M \geq 0 \end{aligned} \quad (1)$$

where $\beta \in \mathbb{R}^+$ is the throughput (inverse of the cycle time, i.e., $\beta = 1/\chi(M)$) and $\alpha \in \mathbb{R}^m$ are the decision variables. Note that LPP (1) provides an exact value for the cycle time of a TMG system $\langle N, M \rangle$. In addition, by simulating the dynamic behavior of a TWMG system [29], the cycle time can also be obtained.

III. TRANSFORMATION OF A TWMG SYSTEM

For a TWMG system, an analytical approach to evaluate the cycle time is to transform it into an equivalent TMG system that has the same cycle time. In [26], Munier proposed a method to convert a TWMG system $\langle N, M \rangle$ (with n places and m transitions) to an equivalent TMG system $\langle \hat{N}, \hat{M} \rangle$ (with \hat{n} places and \hat{m} transitions) whose cycle time is identical. This procedure is shown in Algorithm 1.

As discussed in [30], for a TWMG system the structure of its equivalent TMG depends on the initial marking. In addition, the number of equivalent TMG systems of a TWMG, whose initial marking is not given, increases exponentially with the size of place set, which makes the resource optimization problem where the initial marking is unknown quite difficult to solve².

Example 1: Consider a TWMG N in Fig. 2 whose minimal T-semiflow is $x = (2, 1)^T$. We assume that the initial marking is $M = (2, 0)^T$. According to Algorithm 1, an equivalent TMG system $\langle \hat{N}, \hat{M} \rangle$ is obtained as follows.

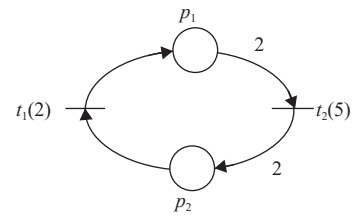

Fig. 2. A TWMG N considered in Examples 1, 2 and 3.

Firstly, for each transition $t_i \in T$ we compute its equivalent subsystem $\langle \hat{N}_{t_i}, \hat{M}_{t_i} \rangle$ as shown in Fig. 3, where

$$\begin{cases} \hat{N}_{t_1} = \{Pre(q_1^1, t_1^1) = 1, Post(q_1^1, t_1^1) = 1, \\ \quad Pre(q_1^2, t_1^1) = 1, Post(q_1^2, t_1^1) = 1\} \\ \hat{M}_{t_1} = [\hat{M}(q_1^1), \hat{M}(q_1^2)]^T = [0, 1]^T \\ \hat{N}_{t_2} = \{Pre(q_2^1, t_2) = 1, Post(q_2^1, t_2) = 1\} \\ \hat{M}_{t_2} = [\hat{M}(q_2^1)]^T = [1]^T \end{cases}$$

² The solutions developed in [30] and [31] for the cycle time optimization have high computational cost since they require one to solve a mixed integer linear programming for each possible equivalent TMG system.

and the equivalent subsystem $\langle \hat{N}_t, \hat{M}_t \rangle$ of transitions can be obtained by the union of each equivalent subsystem $\langle \hat{N}_{t_i}, \hat{M}_{t_i} \rangle$, i.e.,

$$\begin{cases} \langle \hat{N}_t, \hat{M}_t \rangle = \langle \hat{N}_{t_1}, \hat{M}_{t_1} \rangle \cup \langle \hat{N}_{t_2}, \hat{M}_{t_2} \rangle \\ \hat{N}_t = \hat{N}_{t_1} \cup \hat{N}_{t_2} = \{Pre(q_1^1, t_1^1) = 1, Post(q_1^1, t_1^1) = 1, \\ Pre(q_2^1, t_1^1) = 1, Post(q_1^1, t_2^1) = 1, Pre(q_2^1, t_2) = 1, \\ Post(q_2^1, t_2) = 1\} \\ \hat{M}_t = \hat{M}_{t_1} \cup \hat{M}_{t_2} = [\hat{M}(q_1^1), \hat{M}(q_2^1), \hat{M}(q_2^1)]^T. \end{cases}$$

Algorithm 1 [26] Transformation of a TWMG System into an Equivalent TMG System Under Single Server Semantics

Input: A TWMG system $\langle N, M \rangle$ with a minimal T-semiflow $x = (x_1, \dots, x_m)^T$

Output: An equivalent TMG system $\langle \hat{N}, \hat{M} \rangle$ whose cycle time is identical to $\langle N, M \rangle$

1: (Equivalent subsystem $\langle \hat{N}_t, \hat{M}_t \rangle$ of transitions) Replace each transition $t_i \in T$ by x_i transitions, $t_1^1, t_2^1, \dots, t_i^{x_i}$, with delay time

$$\delta(t_i^j) = \delta(t_i), j = 1, \dots, x_i. \quad (2)$$

Add x_i places $q_1^1, \dots, q_i^{x_i}$, where q_i^a ($a = 1, \dots, x_i - 1$) is a place connecting t_i^a to t_i^{a+1} with unitary weights and $q_i^{x_i}$ is a place connecting $t_i^{x_i}$ to t_i^1 with unitary weights.

$$\begin{cases} \hat{M}(q_i^a) = 0, i = 1, \dots, m, a = 1, \dots, x_i - 1 \\ \hat{M}(q_i^{x_i}) = 1. \end{cases} \quad (3)$$

2: (Equivalent subsystem $\langle \hat{N}_p, \hat{M}_p \rangle$ of places: Case 1) Replace each place $p_i \in P$ such that $w(p_i) > v(p_i)$ by $n_i = x_{in(p_i)}$ places p_i^s , where for $s = 1, \dots, n_i$:

$$\begin{cases} a_s \cdot x_{out(p_i)} + b_s = \left\lfloor \frac{M(p_i) + w(p_i) \cdot (s-1)}{v(p_i)} \right\rfloor + 1 \\ b_s \in \{1, \dots, x_{out(p_i)}\} \\ a_s \in \mathbb{N}. \end{cases} \quad (4)$$

Place p_i^s connects transition $t_{in(p_i)}^s$ to transition $t_{out(p_i)}^{b_s}$ and contains a_s tokens, i.e.,

$$\begin{cases} t_{in(p_i^s)} = t_{in(p_i)}^s, \text{ or equivalently } Post(p_i^s, t_{in(p_i)}^s) = 1 \\ t_{out(p_i^s)} = t_{out(p_i)}^{b_s}, \text{ or equivalently } Pre(p_i^s, t_{out(p_i)}^{b_s}) = 1 \\ \mu(p_i^s) = \hat{M}(p_i^s) = a_s. \end{cases} \quad (5)$$

3: (Equivalent subsystem $\langle \hat{N}_p, \hat{M}_p \rangle$ of places: Case 2) Replace each place $p_i \in P$ such that $w(p_i) \leq v(p_i)$ by $n_i = x_{out(p_i)}$ places p_i^s , where for $s = 1, \dots, n_i$:

$$\begin{cases} c_s \cdot x_{in(p_i)} + d_s = \left\lfloor \frac{s \cdot v(p_i) - M(p_i)}{w(p_i)} \right\rfloor \\ d_s \in \{1, \dots, x_{in(p_i)}\} \\ c_s \in \mathbb{Z}_{\leq 0}. \end{cases} \quad (6)$$

Place p_i^s connects transition $t_{in(p_i)}^{d_s}$ to transition $t_{out(p_i)}^s$ and contains $-c_s$ tokens, i.e.,

$$\begin{cases} t_{in(p_i^s)} = t_{in(p_i)}^{d_s} \text{ or equivalently } Post(p_i^s, t_{in(p_i)}^{d_s}) = 1 \\ t_{out(p_i^s)} = t_{out(p_i)}^s \text{ or equivalently } Pre(p_i^s, t_{out(p_i)}^s) = 1 \\ \mu(p_i^s) = \hat{M}(p_i^s) = -c_s. \end{cases} \quad (7)$$

4: (Equivalent TMG system $\langle \hat{N}, \hat{M} \rangle$) The TMG system is equivalent to the union of the subsystems of transitions and places, i.e.,

$$\langle \hat{N}, \hat{M} \rangle = \langle \hat{N}_t, \hat{M}_t \rangle \cup \langle \hat{N}_p, \hat{M}_p \rangle. \quad (8)$$

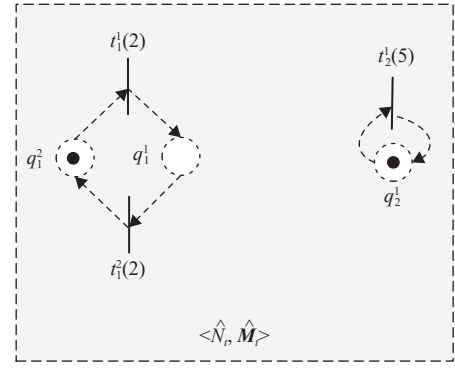

Fig. 3. The equivalent subsystem $\langle \hat{N}_t, \hat{M}_t \rangle$ of transitions.

According to the transformation rule, structures \hat{N}_{t_1} and \hat{N}_{t_2} and their corresponding markings \hat{M}_{t_1} and \hat{M}_{t_2} depend on the net structure N of the TWMG.

Secondly, for each place $p_j \in P$, we compute its equivalent subsystem $\langle \hat{N}_{p_j}, \hat{M}_{p_j} \rangle$ according to (4)–(7) as shown in Fig. 4, where

$$\begin{cases} \hat{N}_{p_1} = \{Pre(p_1^1, t_1^1) = 1, Post(p_1^1, t_1^1) = 1\} \\ \hat{M}_{p_1} = [\hat{M}(p_1^1)]^T = [1]^T \\ \hat{N}_{p_2} = \{Pre(p_2^1, t_1^1) = 1, Post(p_2^1, t_2^1) = 1\} \\ \hat{M}_{p_2} = [\hat{M}(p_2^1)]^T = [0]^T \end{cases}$$

and the equivalent subsystem $\langle \hat{N}_p, \hat{M}_p \rangle$ of places can be obtained by the union of each equivalent subsystem $\langle \hat{N}_{p_j}, \hat{M}_{p_j} \rangle$, i.e.,

$$\begin{cases} \langle \hat{N}_p, \hat{M}_p \rangle = \langle \hat{N}_{p_1}, \hat{M}_{p_1} \rangle \cup \langle \hat{N}_{p_2}, \hat{M}_{p_2} \rangle \\ \hat{N}_p = \hat{N}_{p_1} \cup \hat{N}_{p_2} = \{Pre(p_1^1, t_1^1) = 1, Post(p_1^1, t_1^1) = 1, \\ Pre(p_2^1, t_1^1) = 1, Post(p_2^1, t_2^1) = 1\} \\ \hat{M}_p = \hat{M}_{p_1} \cup \hat{M}_{p_2} = [\hat{M}(p_1^1), \hat{M}(p_2^1)]^T = [1, 0]^T. \end{cases}$$

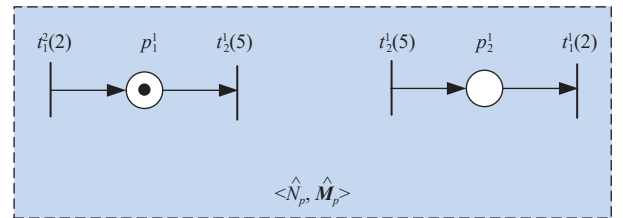

Fig. 4. The equivalent subsystem $\langle \hat{N}_p, \hat{M}_p \rangle$ of places.

Finally, we obtain the equivalent TMG system $\langle \hat{N}, \hat{M} \rangle$ by combining the equivalent subsystems of transitions and places as shown in Fig. 5.

IV. PARAMETRIC TRANSFORMATION OF TWMGs

Since the equivalent structure of the TMG depends on the initial marking of the TWMG, the number of equivalent TMG systems of a TWMG whose initial marking is unknown could increase exponentially with the size of place set. Therefore, it is practically inefficient to solve a resource optimization problem by exploring all the equivalent TMG systems. This section proposes a method to transform a TWMG whose initial marking is not given into an equivalent parametric

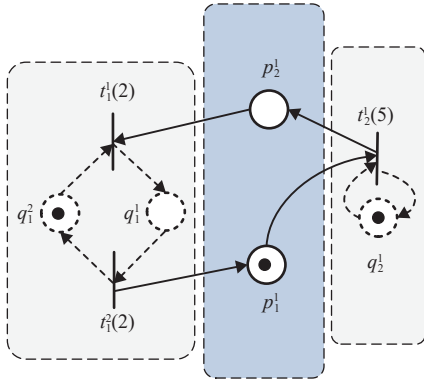

Fig. 5. The equivalent TMG system of the TWMG N depicted in Fig. 2 with $M = [2, 0]^T$.

TMG system. First, we discuss the logic constraints of the possible equivalent subsystems in Section IV-A. Then, some techniques are introduced to convert a TWMG to an equivalent parametric TMG in Section IV-B.

A. Logic Constraints of the Equivalent Subsystems

In [30], the authors prove that the equivalent subsystem $\langle \hat{N}_t, \hat{M}_t \rangle$ of transitions is fixed regardless of the initial marking, while the equivalent subsystem $\langle \hat{N}_{p_i}, \hat{M}_{p_i} \rangle$ of any place p_i is periodic w.r.t. $M(p_i)$ with a period ϕ_i , where

$$\phi_i = v(p_i) \cdot x_{out(p_i)}. \quad (9)$$

The marking space of p_i is divided into ϕ_i / \gcd_{p_i} subsets:

$$\mathcal{M}_{p_i}^{k_i} = \{k_i \cdot \gcd_{p_i} + \xi_i \cdot \phi_i \mid \xi_i \in \mathbb{N}, k_i = 0, \dots, \frac{\phi_i}{\gcd_{p_i}} - 1\}. \quad (10)$$

Thus, for each partition $\mathcal{M}_{p_i}^{k_i}$ we can compute its corresponding equivalent subsystem $\langle \hat{N}_{p_i}^{k_i}, \hat{M}_{p_i}^{k_i} \rangle$ by (4)–(7) and the logic constraints of all the equivalent subsystems are shown as follows:

$$\langle \hat{N}_{p_i}, \hat{M}_{p_i} \rangle = \bigvee_{k_i=0}^{\frac{\phi_i}{\gcd_{p_i}} - 1} \langle \hat{N}_{p_i}^{k_i}, \hat{M}_{p_i}^{k_i} \rangle \quad (11)$$

where \bigvee denotes the logical *or* operator.

In the following example, the logic constraints of the equivalent subsystems corresponding to different marking partitions are discussed.

Example 2: Let us consider the TWMG depicted in Fig. 2. According to (9) and (10), the marking space of place p_1 (respectively, p_2) can be partitioned into two (respectively, two) subsets (due to $\phi_1 = 2$, $\phi_2 = 2$, $\gcd_{p_1} = 1$, and $\gcd_{p_2} = 1$):

$$\begin{cases} \mathcal{M}_{p_1}^0 = \{2\xi_1\}, \mathcal{M}_{p_2}^1 = \{1 + 2\xi_1\}, \xi_1 \in \mathbb{N} \\ \mathcal{M}_{p_1}^1 = \{2\xi_2\}, \mathcal{M}_{p_2}^2 = \{1 + 2\xi_2\}, \xi_2 \in \mathbb{N}. \end{cases}$$

When computing the equivalent subsystem $\langle \hat{N}_{p_1}, \hat{M}_{p_1} \rangle$ of place p_1 , we have the following situations:

1) **If** $M(p_1) = 2\xi_1$, i.e., $M(p_1) \in \mathcal{M}_{p_1}^0$, **then**

$$\begin{cases} \hat{N}_{p_1}^0 = \{Pre(p_1^1, t_1^1) = 1, Post(p_1^1, t_1^1) = 1\} \\ \hat{M}_{p_1}^0 = [\hat{M}(p_1^1)]^T = [\xi_1]^T. \end{cases}$$

2) **If** $M(p_1) = 1 + 2\xi_1$, i.e., $M(p_1) \in \mathcal{M}_{p_1}^1$, **then**

$$\begin{cases} \hat{N}_{p_1}^1 = \{Pre(p_1^1, t_1^1) = 1, Post(p_1^1, t_1^1) = 1\} \\ \hat{M}_{p_1}^1 = [\hat{M}(p_1^1)]^T = [\xi_1]^T. \end{cases}$$

Therefore, the subsystem $\langle \hat{N}_{p_1}, \hat{M}_{p_1} \rangle$ of place p_1 can be represented as follows:

$$\langle \hat{N}_{p_1}, \hat{M}_{p_1} \rangle = \bigvee_{k_1=0}^1 \langle \hat{N}_{p_1}^{k_1}, \hat{M}_{p_1}^{k_1} \rangle.$$

Analogously, the equivalent subsystem $\langle \hat{N}_{p_2}, \hat{M}_{p_2} \rangle$ of place p_2 belongs to one of the following situations:

3) **If** $M(p_2) = 2\xi_2$, i.e., $M(p_2) \in \mathcal{M}_{p_2}^0$, **then**

$$\begin{cases} \hat{N}_{p_2}^0 = \{Pre(p_2^1, t_1^1) = 1, Post(p_2^1, t_1^1) = 1\} \\ \hat{M}_{p_2}^0 = [\hat{M}(p_2^1)]^T = [\xi_2]^T. \end{cases}$$

4) **If** $M(p_2) = 1 + 2\xi_2$, i.e., $M(p_2) \in \mathcal{M}_{p_2}^1$, **then**

$$\begin{cases} \hat{N}_{p_2}^1 = \{Pre(p_2^1, t_1^1) = 1, Post(p_2^1, t_1^1) = 1\} \\ \hat{M}_{p_2}^1 = [\hat{M}(p_2^1)]^T = [\xi_2]^T. \end{cases}$$

Therefore, the equivalent subsystem $\langle \hat{N}_{p_2}, \hat{M}_{p_2} \rangle$ of place p_2 can be represented as follows:

$$\langle \hat{N}_{p_2}, \hat{M}_{p_2} \rangle = \bigvee_{k_2=0}^1 \langle \hat{N}_{p_2}^{k_2}, \hat{M}_{p_2}^{k_2} \rangle.$$

In conclusion, we can represent a TWMG N by an equivalent TMG system $\langle \hat{N}, \hat{M} \rangle$ as follows:

$$\begin{cases} \langle \hat{N}, \hat{M} \rangle = \langle \hat{N}_t, \hat{M}_t \rangle \cup \langle \hat{N}_p, \hat{M}_p \rangle = \langle \hat{N}_{t_1}, \hat{M}_{t_1} \rangle \cup \dots \\ \cup \langle \hat{N}_{t_m}, \hat{M}_{t_m} \rangle \cup \left(\bigvee_{k_1} \langle \hat{N}_{p_1}^{k_1}, \hat{M}_{p_1}^{k_1} \rangle \right) \cup \dots \\ \cup \left(\bigvee_{k_n} \langle \hat{N}_{p_n}^{k_n}, \hat{M}_{p_n}^{k_n} \rangle \right) \text{ where} \\ k_i = 0, \dots, \frac{\phi_i}{\gcd_{p_i}} - 1. \end{cases} \quad (12)$$

B. Parametric Transformation

For each place $p \in P$, the logic constraints of its possible equivalent subsystems are logic or constraints. In particular, all the constraints are equality constraints. In this subsection, some transformation rules to convert logic or constraints into linear constraints are adopted to synthesize all equivalent subsystems into one.

Consider the following equality constraints:

$$\bigvee_{i=1}^s \vec{v}_i = \vec{u}_i, \vec{v}_i, \vec{u}_i \in \mathbb{R}^n. \quad (13)$$

The work in [33]–[35] showed that the above equality constraints can be transformed into following linear constraints:

$$(14) \quad \begin{cases} \vec{v}_1 - \vec{u}_1 \leq z_1 \cdot \vec{h} \\ \vec{v}_1 - \vec{u}_1 \geq -z_1 \cdot \vec{h} \\ \vdots \\ \vec{v}_s - \vec{u}_s \leq z_s \cdot \vec{h} \\ \vec{v}_s - \vec{u}_s \geq -z_s \cdot \vec{h} \\ \sum_{i=1}^s z_i = s - 1 \\ z_i \in \{0, 1\}, i = 1, \dots, s \end{cases}$$

where $\vec{h} \in \mathbb{R}^n$ is a constant vector satisfying

$$h_j > \max |v_i(j) - u_i(j)|, j = \{1, \dots, n\}. \quad (15)$$

If $z_j = 0$, then $\vec{v}_j = \vec{u}_j$ holds, which implies that the j -th constraint is active. On the contrary, if $z_j = 1$, the j -th constraint is redundant. The condition $\sum_{i=1}^s z_i = s - 1$ implies that one and only one constraint is active and all others are redundant.

Combining the results in (14) and (15), a method to transform a TWMG N whose initial marking is unknown into an equivalent parametric TMG system, is developed as follows.

Proposition 1: Let N be a TWMG with minimal T-semiflow $\mathbf{x} = (x_1, \dots, x_m)^T$, and assume its initial marking \mathbf{M} is unknown. The net N can be converted to an equivalent parametric TMG system $\mathcal{G}(\mathbf{M}, \hat{N}, \hat{\mathbf{M}})$ whose cycle time is identical as follows:

$$\mathcal{G}(\mathbf{M}, \hat{N}, \hat{\mathbf{M}}) = \begin{cases} \hat{\mathbf{M}}(q_r^a) = 0, \hat{\delta}(t_r^a) = \delta(t_r) \\ \hat{\mathbf{M}}(q_r^{x_r}) = 1, \hat{\delta}(t_r^{x_r}) = \delta(t_r) \\ \hat{P}re(q_r^a, t_r^{a+1}) = 1, \hat{P}re(q_r^{x_r}, t_r^1) = 1 \\ \hat{P}ost(q_r^a, t_r^a) = 1, \hat{P}ost(q_r^{x_r}, t_r^{x_r}) = 1 \\ r = 1, \dots, m \\ a = 1, \dots, x_r - 1 \end{cases} \quad (16a)$$

$$(16b) \quad \begin{cases} M(p_i) - k_i \cdot gcd_{p_i} - \xi_i \cdot \phi_i \leq z_{i,k_i} \cdot h \\ M(p_i) - k_i \cdot gcd_{p_i} - \xi_i \cdot \phi_i \geq -z_{i,k_i} \cdot h \\ \hat{\mathbf{M}}(p_i^s) - \xi_i - \mu(p_i^s) \leq z_{i,k_i} \cdot h \\ \hat{\mathbf{M}}(p_i^s) - \xi_i - \mu(p_i^s) \geq -z_{i,k_i} \cdot h \\ \hat{P}re(p_i^s, t_{out}(p_i^s)) - 1 \leq z_{i,k_i} \cdot h \\ \hat{P}re(p_i^s, t_{out}(p_i^s)) - 1 \geq -z_{i,k_i} \cdot h \\ \hat{P}ost(p_i^s, t_{in}(p_i^s)) - 1 \leq z_{i,k_i} \cdot h \\ \hat{P}ost(p_i^s, t_{in}(p_i^s)) - 1 \geq -z_{i,k_i} \cdot h \\ s = 1, \dots, n_i \\ i = 1, \dots, n \\ k_i = 0, \dots, \frac{\phi_i}{gcd_{p_i}} - 1 \end{cases}$$

$$(16c) \quad \begin{cases} \sum_{k_i=0}^{\frac{\phi_i}{gcd_{p_i}}-1} z_{i,k_i} = \frac{\phi_i}{gcd_{p_i}} - 1 \\ z_{i,k_i} \in \{0, 1\} \\ \xi_i \in \mathbb{N} \end{cases}$$

where n_i , $t_{out}(p_i^j)$, and $t_{in}(p_i^s)$, obtained according to Algorithm 1, denote the number of equivalent places of p_i , the unique output transition of equivalent place p_i^j , and the unique input transition of equivalent place p_i^s , respectively. Parameter $h \in \mathbb{R}$ is a constant satisfying

$$h > \max\{|M(p_i) - k_i \cdot gcd_{p_i} - \xi_i \cdot \phi_i|, |\hat{\mathbf{M}}(p_i^s) - \xi_i - \mu(p_i^s)|, |\hat{P}re(p_i^s, t_{out}(p_i^s)) - 1|, |\hat{P}ost(p_i^s, t_{in}(p_i^s)) - 1|\}. \quad (17)$$

Proof: Constraint (16a) enforces (2) and (3) in Algorithm 1 that specify the transition equivalence between the TWMG N and the system $\mathcal{G}(\mathbf{M}, \hat{N}, \hat{\mathbf{M}})$. Combining the results in (5), (7) and (14), constraint (16b) enforces the correctness of the place equivalence between the TWMG N and the system $\mathcal{G}(\mathbf{M}, \hat{N}, \hat{\mathbf{M}})$. Although the initial marking \mathbf{M} is unknown, the marking of each place can be partitioned into finite sets as shown in (10). Therefore, constraint (16c) guarantees that all marking partitions of TWMG N are included in system $\mathcal{G}(\mathbf{M}, \hat{N}, \hat{\mathbf{M}})$, which indicates that all the possible equivalent TMG systems can be represented by system $\mathcal{G}(\mathbf{M}, \hat{N}, \hat{\mathbf{M}})$.

Note that constraint set (16) has a solution only if a suitable constant h exists. This problem will be discussed later. ■

Example 3: Consider again the TWMG in Fig. 2. According to Proposition 1, it can be converted into an equivalent parametric system $\mathcal{G}(\mathbf{M}, \hat{N}, \hat{\mathbf{M}})$ as shown in (18), where h is a large enough number. Constraints (18a), (18b), and (18c) represent the equivalent subsystem corresponding to transitions, place p_1 , and place p_2 , respectively.

$$\mathcal{G}(\mathbf{M}, \hat{N}, \hat{\mathbf{M}}) = \begin{cases} \hat{\mathbf{M}}(q_1^1) = 0, \hat{\delta}(t_1^1) = 2, \hat{\mathbf{M}}(q_1^2) = 1 \\ \hat{\delta}(t_1^2) = 2, \hat{\mathbf{M}}(q_2^1) = 1, \hat{\delta}(t_2^1) = 5 \\ \hat{P}re(q_1^1, t_1^1) = 1, \hat{P}ost(q_1^1, t_1^1) = 1\hat{P}re(q_1^2, t_1^1) = 1 \\ \hat{P}ost(q_1^2, t_1^2) = 1, \hat{P}re(q_2^1, t_2^1) = 1\hat{P}ost(q_2^1, t_2^1) = 1 \end{cases} \quad (18a)$$

$$(18b) \quad \begin{cases} M(p_1) - 2\xi_1 \leq z_{1,0} \cdot h, M(p_1) - 2\xi_1 \geq -z_{1,0} \cdot h \\ \hat{P}re(p_1^1, t_2^1) - 1 \leq z_{1,0} \cdot h \\ \hat{P}re(p_1^1, t_2^1) - 1 \geq -z_{1,0} \cdot h \\ \hat{P}ost(p_1^1, t_1^2) - 1 \leq z_{1,0} \cdot h \\ \hat{P}ost(p_1^1, t_1^2) - 1 \geq -z_{1,0} \cdot h \\ \hat{\mathbf{M}}(p_1^1) - \xi_1 \leq z_{1,0} \cdot h, \hat{\mathbf{M}}(p_1^1) - \xi_1 \geq -z_{1,0} \cdot h \\ M(p_1) - 1 - 2\xi_1 \leq z_{1,1} \cdot h \\ M(p_1) - 1 - 2\xi_1 \geq -z_{1,1} \cdot h \\ \hat{P}re(p_1^1, t_2^1) - 1 \leq z_{1,1} \cdot h \\ \hat{P}re(p_1^1, t_2^1) - 1 \geq -z_{1,1} \cdot h \\ \hat{P}ost(p_1^1, t_1^1) - 1 \leq z_{1,1} \cdot h \\ \hat{P}ost(p_1^1, t_1^1) - 1 \geq -z_{1,1} \cdot h \\ \hat{\mathbf{M}}(p_1^1) - \xi_1 \leq z_{1,1} \cdot h, \hat{\mathbf{M}}(p_1^1) - \xi_1 \geq -z_{1,1} \cdot h \\ z_{1,0} + z_{1,1} = 1, z_{1,0}, z_{1,1} \in \{0, 1\}, \xi_1 \in \mathbb{N} \end{cases}$$

$$\begin{cases}
M(p_2) - 2\xi_2 \leq z_{2,0} \cdot h, M(p_2) - 2\xi_2 \geq -z_{2,0} \cdot h \\
\hat{P}re(p_2^1, t_1^1) - 1 \leq z_{2,0} \cdot h \\
\hat{P}re(p_2^1, t_1^1) - 1 \geq -z_{2,0} \cdot h \\
\hat{P}\hat{o}st(p_2^1, t_2^1) - 1 \leq z_{2,0} \cdot h \\
\hat{P}\hat{o}st(p_2^1, t_2^1) - 1 \geq -z_{2,0} \cdot h \\
\hat{M}(p_2^1) - \xi_2 \leq z_{2,0} \cdot h, \hat{M}(p_2^1) - \xi_2 \geq -z_{2,0} \cdot h \\
M(p_2) - 1 - 2\xi_2 \leq z_{2,1} \cdot h \\
M(p_2) - 1 - 2\xi_2 \geq -z_{2,1} \cdot h \\
\hat{P}re(p_2^1, t_1^2) - 1 \leq z_{2,1} \cdot h \\
\hat{P}re(p_2^1, t_1^2) - 1 \geq -z_{2,1} \cdot h \\
\hat{P}\hat{o}st(p_2^1, t_2^1) - 1 \leq z_{2,1} \cdot h \\
\hat{P}\hat{o}st(p_2^1, t_2^1) - 1 \geq -z_{2,1} \cdot h \\
\hat{M}(p_2^1) - \xi_2 \leq z_{2,1} \cdot h, \hat{M}(p_2^1) - \xi_2 \geq -z_{2,1} \cdot h \\
z_{2,0} + z_{2,1} = 1, z_{2,0}, z_{2,1} \in \{0, 1\}, \xi_2 \in \mathbb{N}.
\end{cases} \quad (18c)$$

V. APPLICATION TO THE RESOURCE OPTIMIZATION PROBLEM

A. An Optimal Solution for Marking Optimization

This section demonstrates that the transformation approach discussed in Section IV can be further used to handle the marking optimization of TWMGs [28], [29]. Then, an optimal solution based on mixed integer quadratically constrained programming is developed.

The mathematical model of the marking optimization of a TWMG can be summarized as follows [29]:

$$\begin{aligned}
& \min \mathbf{y}^T \cdot \mathbf{M} \\
& \text{s.t. } \chi(\mathbf{M}) \leq b
\end{aligned} \quad (19)$$

where b is a predefined positive real number that denotes the upper bound of the cycle time, \mathbf{y}_γ represents the minimal P-semiflow corresponding to circuit γ , and $\mathbf{y} = \sum_{\gamma \in \Gamma} \mathbf{y}_\gamma$ is a P-semiflow that is equal to the sum of all minimal P-semiflows. It has been proven in [28] that problem (19) has a solution iff $b \geq \max\{x_i \cdot \delta_i, t_i \in T\}$, where x_i is the component of minimal T-semiflow corresponding to transition t_i and δ_i is the fixed firing delay of transition t_i .

As mentioned in Section III, for a TWMG system $\langle N, \mathbf{M} \rangle$ its cycle time $\chi(\mathbf{M})$ can be analytically solved by converting it to an equivalent TMG. Nevertheless, according to Algorithm 1, to obtain an equivalent TMG system $\langle \hat{N}, \hat{\mathbf{M}} \rangle$, it is necessary to know the initial marking \mathbf{M} . Based on the equivalent parametric TMG system obtained by Proposition 1, we will show how to transform problem (19) into a programming problem.

Proposition 2: Let $(\beta^*, \mathbf{M}^*, \hat{\mathbf{M}}^*, \hat{\mathbf{P}}re^*, \hat{\mathbf{C}}^*, \boldsymbol{\alpha}^*)$ be the optimal solution of the following mixed integer quadratically constrained programming problem:

$$\begin{aligned}
& \min \mathbf{y}^T \cdot \mathbf{M} \\
& \text{s.t.} \\
& \left\{ \begin{array}{l} \hat{\mathbf{C}} \cdot \boldsymbol{\alpha} - \hat{\mathbf{P}}re \cdot \hat{\boldsymbol{\delta}} \cdot \beta + \hat{\mathbf{M}} \geq 0 \\ \beta \geq \frac{1}{b} \end{array} \right. \quad (20a) \\
& \mathcal{G}(\mathbf{M}, \hat{\mathbf{N}}, \hat{\mathbf{M}}) \quad (20c)
\end{aligned} \quad (20b)$$

with variables $\beta \in \mathbb{R}_{\geq 0}$, $\hat{\mathbf{P}}re, \hat{\mathbf{C}} \in \mathbb{Z}^{\hat{n} \times \hat{m}}$, $\mathbf{M} \in \mathbb{N}^n$, $\hat{\mathbf{M}} \in \mathbb{N}^{\hat{n}}$, and $\boldsymbol{\alpha} \in \mathbb{R}^{\hat{m}}$. Then, \mathbf{M}^* is an optimal marking for problem (19).

Proof: The objective function guarantees that the cost of resources is minimized. Constraint (20c) ensures that the parametric TMG system has the same cycle time with the TWMG N . With constraints (20a) and (20b), the cycle time of the equivalent TMG system is not greater than a given upper bound b . It follows that the cycle time of the TWMG system with marking \mathbf{M}^* is not greater than a given upper bound b , namely, $\chi(\mathbf{M}^*) \leq b$. ■

Remark 1: Note that constraint set (20c) has a solution only if a suitable constant h in (17) exists. Since the equivalent parametric TMG system is an ordinary net, it is obvious that $\hat{\mathbf{P}}re, \hat{\mathbf{P}}\hat{o}st \in \{0, 1\}^{\hat{n} \times \hat{m}}$ holds. In [28], it has been proven that a marking \mathbf{M}_f that contains adequate tokens is feasible for problem (19), where $M_f(p) = Pre(p, p^*) \cdot x_{p^*}$, $\forall p \in P$. Thus, this marking is an upper bound of \mathbf{M}^* (i.e., $\mathbf{M}^* \leq \mathbf{M}_f$) and can be used to compute h in (17).

Remark 2: Although an optimal solution of problem (20) $(\beta^*, \mathbf{M}^*, \hat{\mathbf{M}}^*, \hat{\mathbf{P}}re^*, \hat{\mathbf{C}}^*, \boldsymbol{\alpha}^*)$ provides an optimal initial marking \mathbf{M}^* , the quantity $1/\beta^*$ may not be the actual cycle time of the TWMG system. Among all the minimal cost markings that ensure $\beta \geq 1/b$, it is interesting to find one that also maximizes the throughput. This can be done by solving (20) replacing the objective function with "max β " and constraint (20b) with $\mathbf{y}^T \cdot \mathbf{M} = \mathbf{y}^T \cdot \mathbf{M}^*$.

Computational complexity. Although a mixed integer quadratically constrained programming problem belongs to the NP-hard complexity class [36], in practice it can often be efficiently solved by using programming tools such as CPLEX and LINGO. The computational burden of a mixed integer quadratically constrained programming problem is characterized by the numbers of constraints and variables. Problem (20) has $(2 \times \hat{m} \times \hat{n} + 2 \times n + \hat{m} + \hat{n} + \sum_{i=1}^n \phi_i / gcd_{p_i})$ variables at most and $(\sum_{i=1}^n \phi_i / gcd_{p_i} \times (6 \times n_i + 2) + \hat{n} + 1 + 4 \times \hat{m})$ constraints in total, where n_i represents the number of equivalent places of place p_i . It has been proven in [27] that the size of the equivalent TMG is $O(|\mathbf{x}|_1)$, where $|\mathbf{x}|_1$ denotes the 1-norm of the minimal T-semiflow \mathbf{x} . More precisely, we have $\hat{n} \leq 2|\mathbf{x}|_1$ and $\hat{m} = |\mathbf{x}|_1$. Therefore, the number of variables and constraints of problem (20) depends on the numbers of places n and transitions m and the minimal T-semiflow \mathbf{x} of the TWMG.

It is worth mentioning that a mixed integer quadratically constrained programming is a non-convex optimization problem and thus a local optimal solution, which is easy to find, cannot guarantee global optimality [36].

This subsection is concluded with some discussion on its application to the cycle time optimization of TWMGs. Optimal approaches have been developed for TWMGs [30],

[31]. However, these approaches rely on solving mixed integer linear programming for a finite family of equivalent TMGs whose number could increase exponentially w.r.t. that of places. The transformation method proposed in this paper could also be used to the cycle time optimization of TWMGs with a similar technique as Proposition 2.

B. Illustrative Examples

This section applies the proposed approach to the marking optimization of a flexible manufacturing system (FMS) and the obtained results are compared with a previous approach in [29] that is based on the heuristic strategy.

Consider the TWMG of an FMS [28] depicted in Fig. 6. It consists of three machines \mathcal{U}_1 , \mathcal{U}_2 and \mathcal{U}_3 and can manufacture two products, namely \mathcal{R}_1 and \mathcal{R}_2 . The production ratio for \mathcal{R}_1 and \mathcal{R}_2 is 60% and 40%, respectively. The manufacturing processes are as follows: $\mathcal{R}_1 : \mathcal{U}_1, \mathcal{U}_2, \mathcal{U}_3$ (denoted by transitions t_1, t_2 , and t_3 , respectively) and $\mathcal{R}_2 : \mathcal{U}_2, \mathcal{U}_1$ (denoted by transitions t_4 and t_5 , respectively). Transitions t_6, t_7, t_8 , and t_9 are used to represent the cyclic manufacturing process.

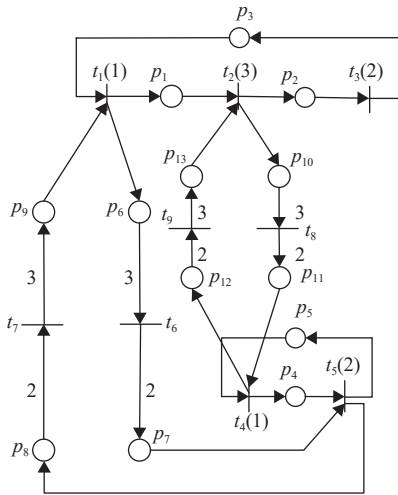

Fig. 6. The TWMG model of a flexible manufacturing system.

We assume that $\mathbf{y} = \sum_{\gamma \in \Gamma} \mathbf{y}_\gamma = [3, 3, 3, 4, 4, 4, 6, 6, 4, 4, 6, 6, 4]^T$ and $b = 11$. The TWMG \mathcal{N} is transformed into an equivalent parametric TMG system $\langle \hat{\mathcal{N}}, \hat{\mathcal{M}} \rangle$ according to Proposition 1. Then, the marking optimization problem is formulated according to Proposition 2 and is solved by using LINGO [37].

In Table I, the proposed approach is compared with the heuristic approach developed in [29] that is implemented by the PN tool HYPENS [38]. All cases run on a computer running Windows 10 with CPU Intel Core i7 at 3.60 GHz and 8 GB RAM. Case 1 is the flexible manufacturing system discussed above, Case 2 is an example taken from Fig. 6 in [29], Case 3 is a flexible manufacturing system studied in [27], and Case 4 is a real assembly line studied in [39] that consists of 41 places and 25 transitions. For each case, the tested approach, the upper bound on the cycle time, the objective function, and the CPU time are shown. Note that the first proposed approach is tested by using LINGO without the

global optimal solver option which means that the obtained solution cannot guarantee the optimality, and the second proposed approach is tested by using LINGO with the global optimal solver option. In Table I, “o.o.t” (out of time) means that the solution cannot be found within 12 hours.

The results in Table I show that the locally optimal solutions obtained by the proposed approach (Loc. Opt.) and the heuristic approach in [29] for Cases 1 and 2 are also global optimal. The solution obtained by the heuristic approach in [29] is better than the locally optimal solution for Case 3, while only a locally optimal solution is found for Case 4. It should be noticed that the computational cost for finding an optimal solution is very high with the increase of the net size. Therefore, a locally optimal solution is also useful.

TABLE I
SIMULATIONS RESULTS OF THE APPROACH IN [29] AND THE
PROPOSED APPROACH

		b	Objective function	CPU time
Case 1	Proposed approach (Loc. Opt.)		38	1.7 s
	Proposed approach (Glob. Opt.)	11	38	38.7 s
	Approach in [29]		38	45.9 s
Case 2	Proposed approach (Loc. Opt.)		28	0.8 s
	Proposed approach (Glob. Opt.)	21	28	4.4 s
	Approach in [29]		28	10.5 s
Case 3	Proposed approach (Loc. Opt.)		315	29.7 s
	Proposed approach (Glob. Opt.)	84	307	5048 s
	Approach in [29]		307	329 s
Case 4	Proposed approach (Loc. Opt.)		40	172.8 s
	Proposed approach (Glob. Opt.)	336	o.o.t	o.o.t
	Approach in [29]		o.o.t	o.o.t

VI. CONCLUSIONS

This work aims to present an approach to transform a TWMG whose initial marking is not given into an equivalent parametric TMG system where the arcs have unitary weights. Using this transformation, a resource optimization problem for the original TWMG can be reduced to an optimization problem for the equivalent parametric TMG, which can be solved more efficiently. Particularly, this approach is used to handle the marking optimization problem of TWMGs and a mixed integer quadratically constrained programming method is developed for the equivalent parametric TMG system. To the best of our knowledge, the existing results for the marking optimization problem of TWMGs are all based on heuristic strategies. Future work aims to extend the developed approach to a general model where shared resources (i.e., conflicts) exist.

REFERENCES

- [1] M. Ibrahim and S. Reveliotis, “Throughput maximization of complex resource allocation systems through timed-continuous-Petri-net modeling,” *Discrete Event Dyn. Syst.*, vol. 29, no. 3, pp. 393–409, 2019.
- [2] N. Ran, H. Y. Su, and S. G. Wang, “An improved approach to test

- diagnosability of bounded Petri nets,” *IEEE/CAA Journal of Automatica Sinica*, vol. 4, no. 2, pp. 297–303, 2017.
- [3] L. Li, F. Basile, and Z. W. Li, “An approach to improve permissiveness of supervisors for GMECs in time Petri net systems,” *IEEE Trans. Autom. Control*, vol. 65, no. 1, pp. 237–251, 2019.
 - [4] D. Wang, X. Wang, and Z. W. Li, “Nonblocking supervisory control of state-tree Sstructures with conditional-preemption matrices,” *IEEE Trans. on Ind. Inf.*, vol. 16, no. 6, pp. 3744–3756, 2020.
 - [5] N. Ran, J. Hao, Z. Dong, Z. He, Z. Liu, Y. Ruan, and S. G. Wang, “Kcodiagnosability verification of labeled Petri nets,” *IEEE Access*, vol. 7, pp. 185055–185062, 2019.
 - [6] J. N. Zhou, J. C. Wang, and J. Wang, “A simulation engine for stochastic timed Petri nets and application to emergency healthcare systems,” *IEEE/CAA Journal of Automatica Sinica*, vol. 6, no. 4, pp. 969–980, 2019.
 - [7] J. C. Wang and D. M. Li, “Resource oriented workflow nets and workflow resource requirement analysis,” *Int. J. Software Engineer. Knowledge Engineer*, vol. 23, no. 5, pp. 667–693, 2013.
 - [8] F. Basile, M. P. Cabasino, and C. Seatzu, “State estimation and fault diagnosis of labeled time Petri net systems with unobservable transitions,” *IEEE Trans. Autom. Control*, vol. 4, no. 60, pp. 997–1009, 2015.
 - [9] R. Li and S. Reveliotis, “Performance optimization for a class of generalized stochastic Petri nets,” *Discrete Event Dyn. Syst.*, vol. 25, no. 3, pp. 387–417, 2015.
 - [10] D. Lefebvre, “Approximated timed reachability graphs for the robust control of discrete event systems,” *Discrete Event Dyn. Syst.*, vol. 29, no. 1, pp. 31–56, 2019.
 - [11] L. Pan, B. Yang, J. Q. Jiang, and M. C. Zhou, “A time Petri net with relaxed mixed semantics for schedulability analysis of flexible manufacturing systems,” *IEEE Access*, vol. 8, pp. 46480–46492, 2020.
 - [12] V. M. Goncalves, C. A. Maia, and L. Hardouin, “On the steady-state control of timed event graphs with firing date constraints,” *IEEE Trans. Autom. Control*, vol. 61, no. 8, pp. 2187–2202, 2016.
 - [13] P. Declerck, “Compromise approach for predictive control of timed event graphs with specifications defined by P-time event graphs,” *Discrete Event Dyn. Syst.*, vol. 26, no. 4, pp. 611–632, 2016.
 - [14] J. Campos, G. Chiola, J. M. Colom, and M. Silva, “Properties and performance bounds for timed marked graphs,” *IEEE Trans. Fundam. Theory Appl.*, vol. 39, no. 5, pp. 386–401, 1992.
 - [15] J. V. Millo and R. De Simone, “Periodic scheduling of marked graphs using balanced binary words,” *Theor. Comput. Sci.*, vol. 458, pp. 113–130, 2012.
 - [16] B. Cottenceau, L. Hardouin, J. L. Boimond, and J. L. Ferrier, “Model reference control for timed event graphs in dioids,” *Automatica*, vol. 37, no. 9, pp. 1451–1458, 2001.
 - [17] B. Cottenceau, L. Hardouin, and J. L. Boimond, “Modeling and control of weight-balanced timed event graphs in dioids,” *IEEE Trans. Autom. Control*, vol. 59, no. 5, pp. 1219–1231, 2014.
 - [18] J. M. Proth, N. Sauer, and X. Xie, “Optimization of the number of transportation devices in a flexible manufacturing system using event graphs,” *IEEE Trans. Ind. Electron.*, vol. 44, no. 3, pp. 298–306, 1997.
 - [19] Z. He, M. Liu, N. Ran, and Z. W. Li, “Firing rate optimization of deterministic timed event graphs by server performance improvement,” *IEEE Access*, vol. 6, pp. 70866–70873, 2018.
 - [20] A. Giua, A. Piccaluga, and C. Seatzu, “Firing rate optimization of cyclic timed event graph,” *Automatica*, vol. 38, no. 1, pp. 91–103, 2002.
 - [21] M. Liu, Z. He, N. Q. Wu, A. Al-Ahmari, and Z. W. Li, “Resource configuration analysis for a class of Petri nets based on strongly connected characteristic resource subnets,” *IEEE Access*, vol. 5, pp. 26376–26386, 2017.
 - [22] Z. W. Li and M. C. Zhou, “On siphon computation for deadlock control in a class of Petri nets,” *IEEE Trans. Syst., Man, Cybern. A, Syst., Humans*, vol. 38, no. 3, pp. 667–679, 2008.
 - [23] Z. W. Li, N. Q. Wu, and M. C. Zhou, “Deadlock control of automated manufacturing systems based on Petri nets—A literature review,” *IEEE Trans. Syst., Man, Cybern. C, Appl. Rev.*, vol. 42, no. 4, pp. 437–462, 2012.
 - [24] B. Cottenceau, L. Hardouin, and J. Trunk, “Weight-balanced timed event graphs to model periodic phenomena in manufacturing systems,” *IEEE Trans. Autom. Sci. Eng.*, vol. 14, no. 4, pp. 1731–1742, 2017.
 - [25] E. Teruel, P. Chrzastowski-Wachtel, J.M. Colom, and M. Silva, “On weighted T-Systems,” *Appl. Theory Petri Nets*, vol. 616, pp. 348–367, 1992.
 - [26] A. Munier, “Régime asymptotique optimal d’un graphe d’événements temporisé généralisé: Application à un problème d’assemblage,” *RAIPOAP II*, vol. 27, pp. 487–513, 1992.
 - [27] M. Nakamura and M. Silva, “Cycle time computation in deterministically timed weighted marked graphs,” in *Proc. 7th IEEE Int. Conf. Emerg. Tech. Factory Autom.*, vol. 2, pp. 1037–1046, 1999.
 - [28] N. Sauer, “Marking optimization of weighted marked graphs,” *Discrete Event Dyn. Syst.*, vol. 13, no. 3, pp. 245–262, 2003.
 - [29] Z. He, Z. W. Li, and A. Giua, “Optimization of deterministic timed weighted marked graphs,” *IEEE Trans. Autom. Sci. Eng.*, vol. 14, no. 2, pp. 1084–1095, 2017.
 - [30] Z. He, Z. W. Li, and A. Giua, “Cycle time optimization of deterministic timed weighted marked graphs by transformation,” *IEEE Trans. Control Syst. Technol.*, vol. 25, no. 4, pp. 1318–1330, 2017.
 - [31] Z. He, Z. W. Li, and A. Giua, “Performance optimization for timed weighted marked graphs under infinite server semantics,” *IEEE Trans. Autom. Control*, vol. 63, no. 8, pp. 2573–2580, 2018.
 - [32] J. H. van Schuppen, M. Silva, and C. Seatzu, “Control of discrete-event systems-automata and Petri net perspectives,” *Lect. Notes Control Infor. Sci.*, Springer, vol. 433, pp. 319–340, 2012.
 - [33] M. P. Cabasino, A. Giua, and C. Seatzu, “Identification of Petri nets from knowledge of their language,” *Discrete Event Dyn. Syst.*, vol. 17, no. 4, pp. 447–474, 2007.
 - [34] A. Bemporad and M. Morari, “Control of systems integrating logic, dynamics, and constraints,” *Automatica*, vol. 35, no. 3, pp. 407–427, 1999.
 - [35] F. Basile, P. Chiacchio, and J. Coppola, “Identification of time Petri net models,” *IEEE Trans. Syst., Man, Cybern. A, Syst.*, vol. 47, no. 9, pp. 2586–2600, 2017.
 - [36] M. Tawarmalani and N. V. Sahinidis, “Global optimization of mixedinteger nonlinear programs: A theoretical and computational study,” *Math. Program.*, vol. 99, no. 3, pp. 563–591, 2004.
 - [37] Lindo Systems Inc., *Lingo User’s Guide*, 2011. [Online]. Available: <http://www.lindo.com>, Accessed on: Mar. 2017.
 - [38] F. Sessego, A. Giua, and C. Seatzu, “HYPENS: a Matlab tool for timed discrete, continuous and hybrid Petri nets,” in *Proc. Int. Conf. Appl. Theor. Petri Nets*, pp. 419–428, 2008.
 - [39] Z. He, Z. Y. Ma, and W. Tang, “Performance safety enforcement in strongly connected timed event graphs,” *Automatica*, under review, 2020.



Zhou He (S’16–M’18) received the B.S. degree in mechanical engineering from the Shaanxi University of Science and Technology, Xi’an, China in 2012, the Ph.D. degree in mechatronic engineering from Xidian University, Xi’an, China in 2017, and the Ph.D. degree in automatique from Aix-Marseille University, Marseille, France in 2017. He is currently an Associate Professor with the College of Mechanical and Electrical Engineering, Shaanxi University of Science and Technology, Xi’an, China.

His research interests include Petri nets, fault diagnosis, and the control and optimization of timed discrete event systems.

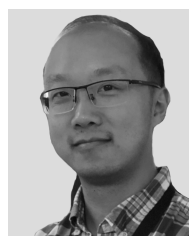

Ziyue Ma (S’15–M’17) received the B.S. and the M.S. degrees from Peking University, China in 2007 and 2011, respectively. In 2017 he got the Ph.D. diploma in cotutorship between the School of Electro-Mechanical Engineering of Xidian University, China (mechatronic engineering), and the Department of Electrical and Electronic Engineering of University of Cagliari, Italy (electronics and computer engineering). He joined Xidian University in 2011, where he is currently an Associate Professor

in the School of Electro-Mechanical Engineering. His current research interests include control theory in discrete event systems, automata and Petri

nets, diagnosis and diagnosability analysis, optimization, and security in cyber-physical systems.

He is a member of Technical Committee Member of IEEE Control System Society (IEEE-CSS) on Discrete Event Systems. He is serving/has served as the Associate Editor of the *IEEE Conference on Automation Science and Engineering* (CASE'17–CASE'20), *European Control Conference* (ECC'19), and *IEEE International Conference on Systems, Man, and Cybernetics* (SMC'19). He is/was the Track Committee Member of the International Conference on Emerging Technologies and Factory Automation (ETFA'17–ETFA'20). He received the Outstanding Reviewer Award from the *IEEE Transactions on Automatic Control*.



Zhiwu Li (M'06–SM'07–F'16) received the B.S., M.S. and Ph.D. degrees in mechanical engineering, automatic control, and manufacturing engineering, respectively, all from Xidian University, Xi'an, China, in 1989, 1992, and 1995, respectively. He joined Xidian University in 1992 and now he is also with the Institute of Systems Engineering, Macau University of Science and Technology, Macau, China. Over the past decade, he was a Visiting Professor at the University of Toronto, Technion (Israel Institute of Technology), Israel, Martin-Luther University of Halle–Wittenburg, Germany, Conservatoire National des Arts et Métiers (CNAM), France, Meliksah Saud University, Turkey. His current research interests include Petri net theory and application, supervisory control of discrete event systems, workflow modeling and analysis, system reconfiguration, game theory, and data and process mining.

He is a member of Discrete Event Systems Technical Committee of the IEEE Systems, Man, and Cybernetics Society, and a member of IFAC Technical Committee on Discrete Event and Hybrid Systems from 2011 to

2014. He serves as a frequent reviewer for 40+ international journals including *Automatica* and a number of the IEEE Transactions as well as many international conferences. He is listed in Marquis Who's Who in the world, 27th Edition, 2010. He is a recipient of an Alexander von Humboldt Research Grant, Alexander von Humboldt Foundation, Germany, and Research in Paris, France. He is the Founding Chair of Xi'an Chapter of IEEE Systems, Man, and Cybernetics Society.



Alessandro Giua (M'92–SM'08–F'17) received a *laurea* degree from the University of Cagliari, Italy in 1988, and the Master and Ph.D. degrees in computer and systems engineering from Rensselaer Polytechnic Institute Troy, NY, USA in 1990 and 1992. He is a Professor of Automatic Control at the Department of Electrical and Electronic Engineering (DIEE) of the University of Cagliari, Italy. He has also held faculty or visiting positions in several institutions worldwide, including Aix-Marseille University, France and Xidian University, Xi'an, China. His research interests include discrete event systems, hybrid systems, networked control systems, Petri nets and failure diagnosis.

He serves the Institute of Electrical and Electronic Engineers (IEEE) as Vice President for Conference Activities of the Control Systems Society (CSS) and the International Federation of Automatic Control (IFAC) as a member of the Publications Committee. He is currently Editor in Chief of the IFAC journal *Nonlinear Analysis: Hybrid Systems*, a Senior Editor of the *IEEE Transaction on Automatic Control*, and a department editor of the journal *Discrete Event Dynamic Systems*. He is a Fellow of the IEEE and a Fellow of the IFAC for contributions to Discrete Event and Hybrid Systems. He is a recipient of the People's Republic of China Friendship Award and of the Shaanxi government Sanqin Friendship Award.